

ROOF
roof panel: profiled sheet metal #1,5; galvanized, coated
mineral wool thickness: 80
sandwich panels in metal plates with styrofoam core, panel thickness: 50mm, galvanized, covered with polyester coating

EXTERNAL WALLS
sandwich panels in metal plates with styrofoam core, panel thickness: 75mm, galvanized, covered with polyester coating

FLOOR
covering PCV Tarkett Rekord 42
OSB3 plate #22
mineral wool/styrofoam #120
cold formed steel crossmembers
bottom: galvanized metal sheet #0,5

- Symbols Description:
- DZ MZ –external steel door's (Hormann MZ)
 - KWS –gravitational ventilation grate UNDER THE CEILING
 - RG –electric distribution box
 - PE –electrical connection (hermetic box on the outside wall)

DIMENSIONAL TOLERANCE ±20mm

This drawing is property of "ANGA" sp. z o. o. Kartuska 393, 80-125 Gdańsk, Poland and shall not be copied by any process, shall not be shown to third party, nor shall it be used for production documentation for any other account without our permission in writing.

Konstruował Designed	Radosław Zdun	11.2017		Nazwa wyrobu/Product name	Masa wyrobu kg Total weight kg
Sprawdził Checked				Gatehouse container	
Zatwierdził Approved	Andrzej Mokrzyński	11.2017		Typ wyrobu/Product type	Format
				Gatehouse container KP-ST	A3
				Nr rysunku/Drawing no.	Edycja Revision
				KP-ST-01	01
					Nr arkusza Sheet no.
					1/2

ANGA sp. z o.o.
ul. Kartuska 393
80-125 Gdańsk
anga@anga.pl

View A

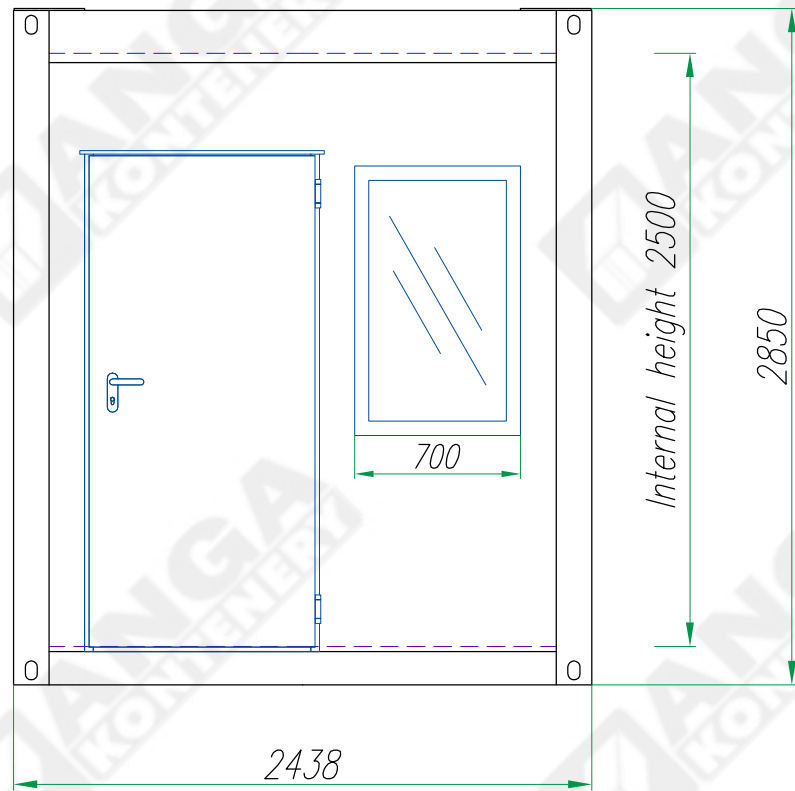

View B

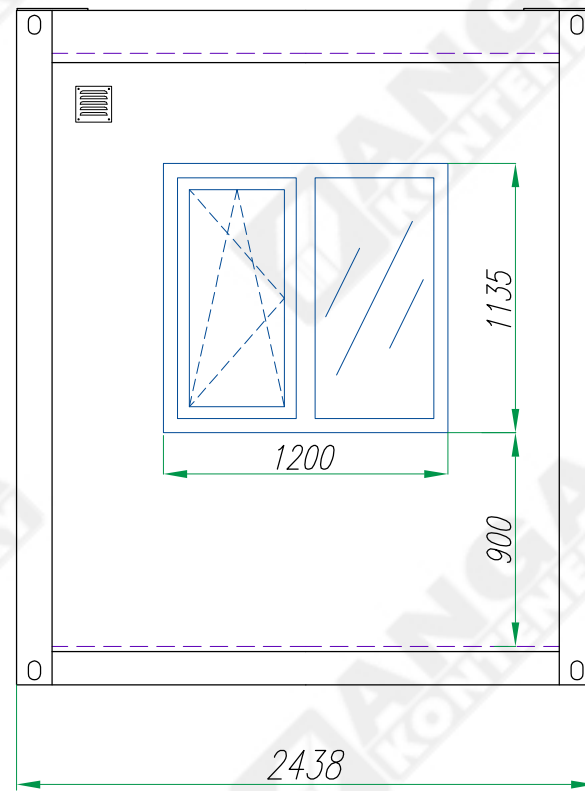

View C

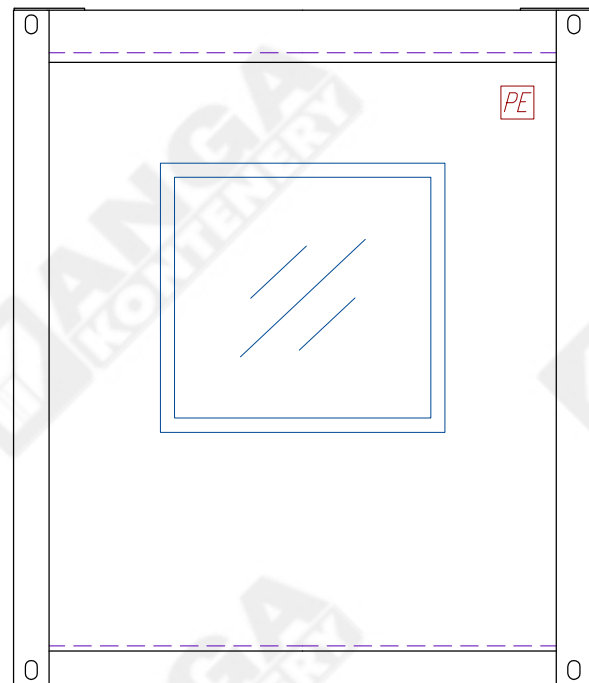

View D

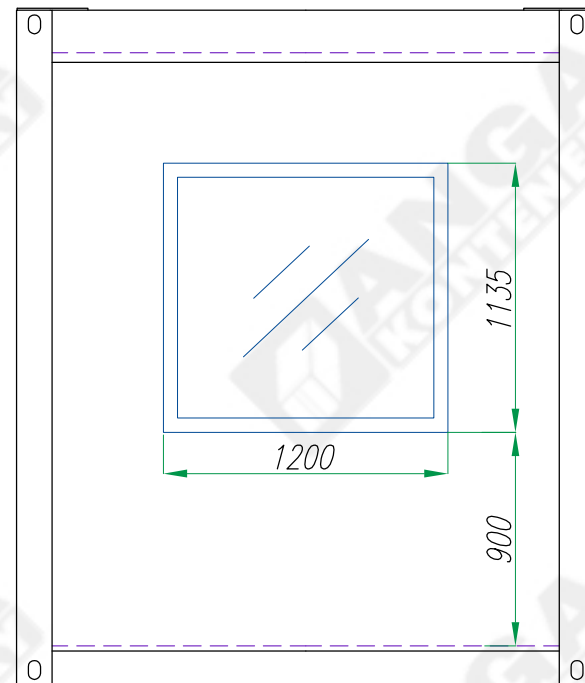
**ROOF**

roof panel: profiled sheet metal #1,5; galvanized, coated

mineral wool thickness: 80

sandwich panels in metal plates with styrofoam core,
panel thickness: 50mm, galvanized, covered with polyester coating

EXTERNAL WALLS

sandwich panels in metal plates with styrofoam core,
panel thickness: 75mm, galvanized, covered with polyester coating

FLOOR

covering PCV Tarkett Rekord 42

OSB3 plate #22

mineral wool/styrofoam #120

cold formed steel crossmembers

bottom: galvanized metal sheet #0,5

DIMENSIONAL TOLERANCE $\pm 20\text{mm}$

This drawing is property of "ANGA" sp. z o. o. Kartuska 393,
80-125 Gdańsk, Poland and shall not be copied
by any process, shall not be shown to third party, nor shall
it be used for production documentation for
any other account without our permission in writing.

Konstruował Designed	Radosław Zdun	11.2017		Nazwa wyrobu/Product name	Masa wyrobu kg Total weight kg
Sprawdził Checked				Gatehouse container	
Zatwierdził Approved	Andrzej Mokrzyński	11.2017		Typ wyrobu/Product type	Format
				Gatehouse container KP-ST	A3
	Nazwisko/Name	Data/Date	Podpis/Signature	Nr rysunku/Drawing no.	Edycja Revision
				KP-ST-01	01
					Nr arkusza Sheet no.
					2/2



ANGA sp. z o.o.
ul. Kartuska 393
80-125 Gdańsk
anga@anga.pl